

## Reconfigurable Compute Fabric (RCF) Devices

# MRC6011

Ushering in a new era in signal processing, the 24 Giga MACS MRC6011 is Freescale's first Reconfigurable Compute Fabric (RCF) device. Ideally suited for MIPS-intensive, repetitive tasks, the MRC6011 offers a resource-efficient solution for computationally intensive applications, such as baseband processing for 2.5G and 3G basestations; broadband wireless access systems; and signal processing for advanced features such as Adaptive Antenna (AA) and Multi-User Detection (MUD). The highly programmable MRC6011 device offers system-level flexibility and scalability while inducing competitive cost and power consumption metrics.

The MRC6011 consists of six RCF cores, an optimized memory subsystem and specialized external interfaces. Each RCF core consists of an array of 16 reconfigurable cells (RCs) connected through an extremely flexible and high-bandwidth fabric. The core also features high-speed local buffers and a RISC processor.

The MRC6011 device complements traditional DSPs in an efficient system-level solution. The MRC6011 is designed to process MIPS-intensive, repetitive tasks and a DSP, such as the MSC8126, performs higher complexity, irregular tasks. The C and assembly programmability of the MRC6011 helps ensure flexibility, ease of programming and integrated tools at the system level, which can result in low total cost of ownership for equipment manufacturers.

RCF CORE BLOCK DIAGRAM

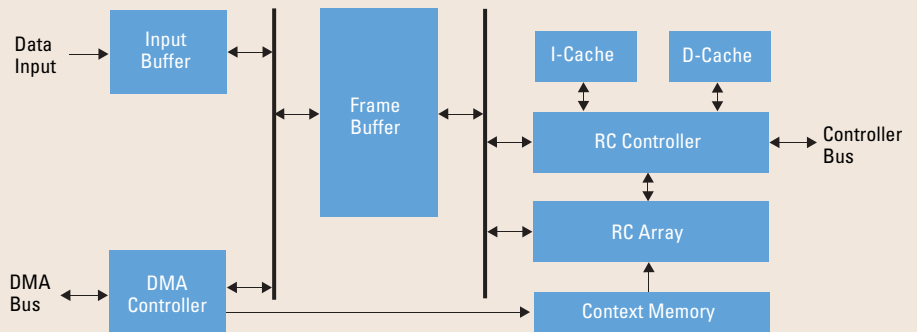

### RCF Core-Level Features

- > Optimized RISC processor for efficient C code compilation
  - Instruction and data cache
- > RC array of 16 RC cells, each featuring:
  - Pipelined MAC unit
  - Arithmetic, logical and conditional units
  - Special-purpose complex correlation unit

- > Large I/O buffers
- > Single and burst transfer DMA controller

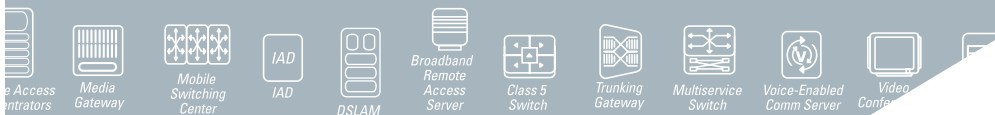

## MRC6011 BLOCK DIAGRAM

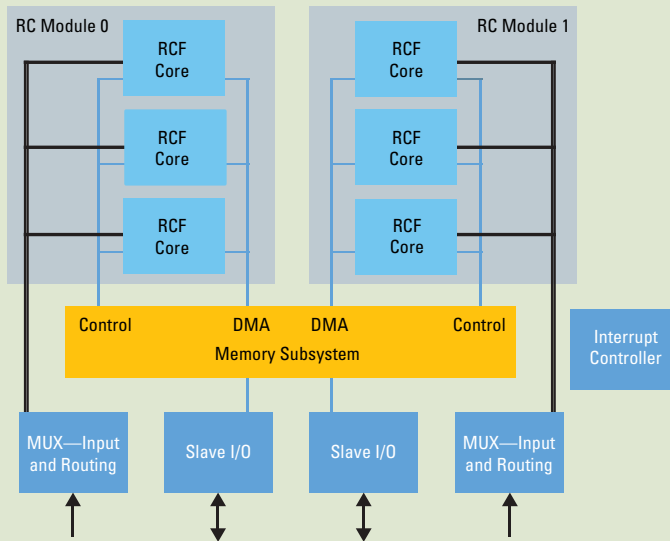

### Device-Level Features

- > Six RCF cores in two modules of three cores
- > Two multiplexed data input (MDI) interfaces
- > Two slave I/O bus interfaces
- > Host visible memory for control code and for traffic sharing
- > Inter-module DMA-based data sharing
- > Single clock input and JTAG support
- > 0.13 $\mu$  process technology
- > Internal logic voltage of 1.2V and I/O voltage of 3.3V
- > 31 mm x 31 mm Tape Ball Grid Array (TBGA) package
- > Under 3W typical power consumption

### Benefits

- > Up to 24 Giga 16-bit MACS of processing power at 250 MHz
- > Up to 48 Giga 4-bit complex correlations per second at 250 MHz
- > High throughput and specialized interfaces for basestation applications
- > Programmability in C and assembly ensures:
  - Field-upgradability
  - Flexibility to support multiple standards
  - Flexibility to add advanced features later
- > Scalable architecture
- > Glueless connectivity to industry standard DSPs
- > Software tools and application modules
  - Metrowerks' award-winning Integrated Development Environment (IDE)
  - Real-time debug capability for each RCF core
- > Library of functions and modules for 3G baseband and other applications



The MRC6011 device offers the benefits of a programmable DSP solution for baseband processing, while zeroing in on the cost, power consumption and processing capability of a traditional ASIC-based approach.

**Learn More:** For more information about Freescale products, please visit [www.freescale.com](http://www.freescale.com).