

PNA-3303

3U Communication Appliance Server with 3 LANs and One PCI Expansion Slot



Specification

Processor

Flexible processor support ranging from the Intel® Celeron® processor at 566 MHz to the Pentium® III processor at 866 MHz with support for 66/100/133 MHz Processor System Bus (PSB)

Memory

- Support for 100 and 133 MHz SDRAM
- 512 MB SODIMM maximum memory

I/O Ports

- 3 Intel® 82559ER Ethernet LAN connect interface
- Two USB ports
- One RS-232

Storage Device

- Two 3.5" Hard disk Bay
- Embedded DOM socket

PCI Expansion

One PCI expansion slot

LEDs

8 user self defined programming LEDs

Power

External 70W AC/DC power adapter

Operating Environment

- Temperature: 5 to 45°C
- Humidity: 20% to 90% RH

Storage Environment

- Temperature: 5 to 70°C
- Humidity : 5% to 95%

Dimension

- 144(W) x 260(D) x 130(H)mm
- 5.7"(W) x 10.2"(W) x 5.1"(H)

Safety

CE/FCC

Highlights

Designed based on Intel® Proof of concept architecture platform

Three Embedded Intel® 10/100 Ethernet for easy I/O configuration

Embedded storage capability design for DOM usage

Dual Hard Disk Drive Bay design

Tailor-made redirect to console BIOS allows users to operate system via a com port

Both desktop and Rack-mount form factor with Good system ventilation design

3 units stacked side-by-side fit a 19" 3U rack

One PCI expansion slot

One SODIMM socket

One optional VGA output

Ordering Guide

PNA-3303-0000

3U communication appliance server with three LANs and one PCI expansion slot (CPU and RAM not included)

PNA-3303

Communications Appliance

User's Manual

Version 010



Portwell Inc.

3F, No. 92, Sec. 1, Nei-Hu Rd., Taipei 114, Taiwan, R.O.C.
Headquarter: +886-2-2799-2020 FAX: +886-2-2799-1010
<http://www.portwell.com.tw>
Email: info@mail.portwell.com.tw



B8980580

Table of Contents

Chapter 1	Introduction	2
	1.1 <i>About This Manual</i>	2
	1.2 <i>Manual Organization</i>	2
	1.3 <i>Technical Support Information</i>	2
Chapter 2	Getting Started	3
	2.1 <i>Included Hardware</i>	3
	2.2 <i>Before You Begin</i>	3
	2.3 <i>The Chassis</i>	4
	2.4 <i>Opening the Chassis</i>	4
	2.5 <i>Installing or Removing a SODIMM</i>	5
	2.6 <i>Remove and Install DOM</i>	6
	2.7 <i>Remove and Install Battery</i>	6
	2.8 <i>Remove and Install HDD</i>	7
	2.9 <i>Remove and Install PCI card</i>	8
	2.10 <i>Product Specifications</i>	11
	2.11 <i>Hardware Configuration Setting</i>	12
	2.12 <i>Install a Different Processor</i>	17
	2.13 <i>Use a Client Computer</i>	18
Chapter 3	Operation Guide.....	20
	3.1 <i>Brief Guide of PPAP-200</i>	20
	3.2 <i>System Architecture</i>	21

Chapter 1 Introduction

1.1 About This Manual

This manual describes all required information for setting up and using the PNA-3303.

PNA-3303 provides the essential components for delivering optimal performance and functionality in the value communications appliance market segment. This manual should familiarize you with PNA-3303 operations and functions. PNA-3303 has three on-board LAN ports to serve communication appliances, such as Firewall, which needs three LAN ports to connect external network (internet), demilitarized zone and internal network.

Feature of PNA-3303 includes:

- ◆ Versatile networking and I/O capabilities: 3 Ethernet ports
- ◆ Two USB ports
- ◆ One COM port
- ◆ Up to 256 Mbyte of SODIMM memory
- ◆ One on-board DMA/33/66/100 IDE channel to support up to four IDE devices
- ◆ One PCI right-angle connector for ease of connectivity to the PCI bus

1.2 Manual Organization

The manual describes how to configure your PNA-3303 system to meet various operating requirements. It is divided into three chapters, with each chapter addressing a basic concept and operation of this whole system.

Chapter 1: Introduction. This section briefly talks about how this document is organized. It includes some guidelines for users who do not want to read through everything, but still helps you find what you need.

Chapter 2: Hardware Configuration Setting and Installation. This chapter shows how the hardware is put together, including detailed information. It shows the definitions and locations of Jumpers and Connectors that you can easily configure your system. Descriptions on how to properly mount the CPU and main memory are also included to help you get a safe installation. Reading this chapter will teach you how to set up PNA-3303.

Chapter 3: Operation Information. This section gives you illustrations and more information on the system architecture and how its performance can be maximized.

Any updates to this manual, technical clarification and answers to frequently asked questions would be posted on the web site: <http://isc.portwell.com.tw>

1.3 Technical Support Information

Users may find helpful tips or related information on Portwell's web site: <http://www.portwell.com.tw>. A direct contact to Portwell's technical person is also available. For further support, users may also contact Portwell's headquarter in Taipei or your local distributors.

Taipei Office Phone Number: +886-2-27992020

Chapter 2 Getting Started

This section describes how the hardware installation and system settings should be done.

2.1 Included Hardware

The following hardware is included in your kit:

- ◆ PPAP-200 Communication Appliance System Board
- ◆ AC to 15V DC adapter
- ◆ One null serial port cable

2.2 Before You Begin

To prevent damage to any system board, it is important to handle it with care. The following measures are generally sufficient to protect your equipment from static electricity discharge:

When handling the board, use a grounded wrist strap designed for static discharge elimination and touch a grounded metal object before removing the board from the antistatic bag. Handle the board by its edges only; do not touch its components, peripheral chips, memory modules or gold contacts.

When handling processor chips or memory modules, avoid touching their pins or gold edge fingers. Put the value communications appliance system board and peripherals back into the antistatic bag when they are not in use or not installed in the chassis.

Some circuitry on the system board can continue operating even though the power is switched off. Under no circumstances should the Lithium coin cell used to power the real-time clock be allowed to be shorted. The coin cell can heat under these conditions and present a burn hazard.

WARNING!

1. **"CAUTION: DANGER OF EXPLOSION IF BATTERY IS INCORRECTLY REPLACED. REPLACE ONLY WITH SAME OR EQUIVALENT TYPE RECOMMENDED BY THE MANUFACTURER. DISCARD USED BATTERIES ACCORDING TO THE MANUFACTURER'S INSTRUCTIONS"**
2. **This guide is for technically qualified personnel who have experience installing and configuring system boards. Disconnect the system board power supply from its power source before you connect/disconnect cables or install/remove any system board components. Failure to do this can result in personnel injury or equipment damage.**
3. **Avoid short-circuiting the lithium battery; this can cause it to superheat and cause burns if touched.**
4. **Do not operate the processor without a thermal solution. Damage to the processor can occur in seconds.**
5. **Do not block air vents. Minimum 1/2-inch clearance required.**

2.10 Product Specifications

Model:	PNA-3303
Main Processor:	<ul style="list-style-type: none">• Intel® socket 370 FC-PGA Celeron®/Pentium® III processors (66, 100 or 133MHz system bus)
BIOS:	<ul style="list-style-type: none">• Award system BIOS with 512KB flash ROM to support DMI, PnP, APM function
Main Memory:	<ul style="list-style-type: none">• One 144-pin SODIMM socket supports up to 512MB of 3.3V SODIMM
L2 Cache Memory:	<ul style="list-style-type: none">• 128KB/256KB PBSRAM built in (Celeron/Pentium III) CPU module
Chipset:	<ul style="list-style-type: none">• Intel® 815E
PCI IDE Interface:	<ul style="list-style-type: none">• One 3.5" hard disk bay for DMA/33/66/100 IDE hard disk
Serial Ports:	<ul style="list-style-type: none">• Support two high-speed 16C550 compatible UARTs with 16-byte T/R FIFOs• (Optional) Support LCD/Key pad module (Portwell proprietary)
USB Interface:	<ul style="list-style-type: none">• Support two USB ports for high speed I/O peripheral devices
Auxiliary I/O Interfaces:	<ul style="list-style-type: none">• System reset switch, power okay LED, Ethernet activity LED, Ethernet speed LED, general purpose LED, alert LED and HDD LED interface
Power Input:	<ul style="list-style-type: none">• Support one DC input jack (power requirement: DC 15V, 4.6A)
PCI Slot:	<ul style="list-style-type: none">• One PCI slot for add-on PCI card
On-board Ethernet:	<ul style="list-style-type: none">• Two Intel® 82559ER 10/100 Base-T fast Ethernet controller with RJ-45 interface• One Intel® 82801BA (Internal MAC) + 82562ET (PHY) 10/100 Base-T fast Ethernet controller with RJ-45 interface
Main Memory:	<ul style="list-style-type: none">• One 144-pin SODIMM socket supports up to 512MB of 3.3V SODIMM
Hardware Monitor:	Support on-board hardware monitor for <ul style="list-style-type: none">• CPU fan x 1• Chassis fan x 2• System voltages: Vcore, 3.3V, 1.8V, +5V and +12V
Power Good:	<ul style="list-style-type: none">• On-board power good interval: 140ms ~ 300ms; typical 200ms
Environmental Requirements:	<ul style="list-style-type: none">• Operating Temperature: 5°C ~ 45°C• Storage Temperature: 5°C ~ 70°C• Relative Humidity: 5% ~ 95%, non-condensing
Dimension:	<ul style="list-style-type: none">• 5.12"(L) x 8.5"(W)

2.11 Hardware Configuration Setting

This section gives the definitions and shows the positions of jumpers, headers and connectors. All of the configuration jumpers on PPAP-200 are in the proper position. The default settings set by factory are marked with a star (★).



Jumpers

In general, jumpers on PPAP-200 system board are used to select options for certain features. Some of the jumpers are configurable for system enhancement. The others are for testing purpose only and should not be altered. To select any option, cover the jumper cap over (Short) or remove (NC) it from the jumper pins according to the following instructions. Here NC stands for “Not Connected”. (Please refer to **Fig. 2-43** for detailed jumper positions.)

Jumper Setting Table (JP1/JP2/JP3)

JP1	Clear CMOS RAM	Default Setting
1-2	Normal	★
2-3	Clear CMOS RAM	

JP2	CPU Frequency Strapping Default Setting	Default Setting
Short	Force CPU Frequency to safe mode	
N/C	Use CPU Frequency strapping in ICH2 Register	★

JP3	FWH Top Block Lock	Default Setting
Short	Top Block Unlock	★
N/C	Top Block Lock	

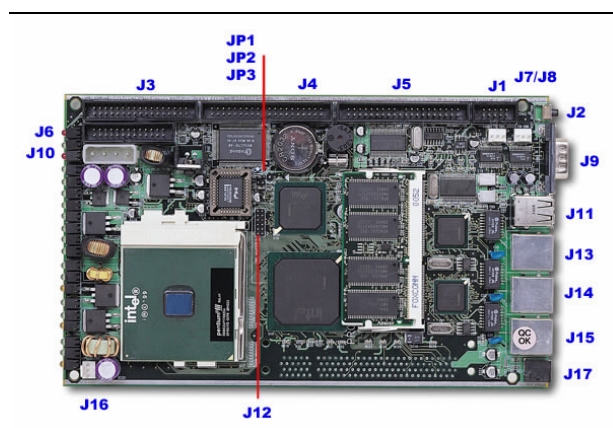

Fig. 2-43 Jumper Position



Connectors

Devices are connected through these connectors which includes IDE, COM Port etc...

Connector	Function	Remark
J1	Serial ports connector	Shrouded pin header
J2	Reset push button	
J3	FDC connector	
J4	Secondary IDE connector	
J5	Primary IDE connector	
J6	Parallel port connector	
J7	Chassis fan connector	
J8	Chassis fan connector	
J9	Serial ports connector	D-SUB 9
J10	Power output connector	Supply power to IDE/FDC Interface
J11	Dual USB port connector	
J12	VGA board connector	Need a CRT module for VGA display
J13	Ethernet connector	
J14	Ethernet connector	
J15	Ethernet connector	
J16	CPU fan	
J17	Power jack	
J18	Right angle PCI bus connector	



Pin Assignments of Connectors

J1/J9: Serial Port Connector

PIN No.	Signal Description
1	DCD
2	RXD
3	TXD
4	DTR
5	SGND
6	DSR
7	RTS
8	CTS
9	RI
10	N/C (J1 only)

J2: Reset Push Button (Momentary)

PIN No.	Signal Description
1	Reset signal
2	Ground

J3: FDC Connector

PIN No.	Signal Description	PIN No.	Signal Description
1	Ground	2	Density0#
3	Ground	4	N/C
5	Ground	6	Density1#
7	Ground	8	INDEX#
9	Ground	10	MOA#
11	Ground	12	DSB#
13	Ground	14	DSA#
15	Ground	16	MOB#
17	Ground	18	DIR#
19	Ground	20	STEP#
21	Ground	22	WD#
23	Ground	24	WE#
25	Ground	26	TRACK0#
27	Ground	28	WP#
29	N/C	30	RDATA#
31	Ground	32	HEAD#
33	N/C	34	DSKCHG#

J4/J5: IDE Connector

PIN No.	Signal Description	PIN No.	Signal Description
1	RESET#	2	Ground
3	Data 7	4	Data 8
5	Data 6	6	Data 9
7	Data 5	8	Data 10
9	Data 4	10	Data 11
11	Data 3	12	Data 12
13	Data 2	14	Data 13
15	Data 1	16	Data 14
17	Data 0	18	Data 15
19	Ground	20	+5V
21	DMAREQ	22	Ground
23	IOW#	24	Ground
25	IOR#	26	Ground
27	IOCHRDY	28	Ground
29	DMAACK#	30	Ground
31	IRQ15/14	32	N/C
33	SA1	34	PDIAG#1CSEL
35	SA0	36	SA2
37	HDCCSO#	38	HDCCS1#
39	HDDACTIVE#	40	Ground

J6: Parallel Connector

PIN No.	Signal Description	PIN No.	Signal Description
1	Strobe#	14	AFD#
2	Data 0	15	ERR#
3	Data 1	16	INIT#
4	Data 2	17	SLIN#
5	Data 3	18	Ground
6	Data 4	19	Ground
7	Data 5	20	Ground
8	Data 6	21	Ground
9	Data 7	22	Ground
10	ACK#	23	Ground
11	BUSY	24	Ground
12	PE	25	Ground
13	SLCT	26	N/C

J7/J8/J16: Fan Connector

PIN No.	Signal Description
1	Ground
2	+12V
3	TachoMeter Signal

J10 : Power Output Connector (To provide IDE, FDC Interface power)

PIN No.	Signal Description
1	+12V
2	Ground
3	Ground
4	+5V

J11: Dual USB Port Connector

PIN No.	Signal Description	PIN No.	Signal Description
1	+5V	5	+5V
2	USB D0-	6	USB D0-
3	USB D0+	7	USB D0+
4	Ground	8	Ground

J12: VGA Connector

PIN No.	Signal Description	PIN No.	Signal Description
1	VID_RED	2	Ground
3	VID_GREEN	4	+1.8V
5	VID_BLUE	6	Ground
7	Ground	8	3VDDCDA
9	3VDDCCL	10	CRT_HSYNC
11	CRT_VSYNC	12	+5V

J13/J14/J15: Ethernet Connector

PIN No.	Signal Description	PIN No.	Signal Description
1	TX+	2	TX-
3	RX+	4	Termplane
5	Termplane	6	RX-
7	Termplane	8	Termplane

J17: Power Jack Connector

PIN No.	Signal Description
1	+15V
2	Ground
3	Ground

J18: PCI Bus Connector

PIN No.	Signal Description	PIN No.	Signal Description
B1	N/C	A1	PTRST#
B2	PTCK	A2	+12V
B3	Ground	A3	PTMS
B4	N/C	A4	PTDI
B5	+5V	A5	+5V
B6	+5V	A6	PIRQ#B
B7	PIRQ#C	A7	PIRQ#D
B8	PIRQ#A	A8	+5V
B9	N/C	A9	N/C
B10	N/C	A10	+5V
B11	N/C	A11	N/C
B12	Ground	A12	Ground
B13	Ground	A13	Ground
B14	N/C	A14	N/C
B15	Ground	A15	PCIRST#
B16	PCICLK	A16	+5V
B17	Ground	A17	PGNT#0
B18	PREQ#0	A18	Ground
B19	+5V	A19	N/C
B20	AD31	A20	AD30
B21	AD29	A21	N/C
B22	Ground	A22	AD28
B23	AD27	A23	AD26
B24	AD25	A24	Ground
B25	N/C	A25	AD24
B26	C_BE#3	A26	IDSEL (Connected to AD31)
B27	AD23	A27	N/C
B28	Ground	A28	AD22
B29	AD21	A29	AD20
B30	AD19	A30	Ground
B31	N/C	A31	AD18

B32	AD17	A32	AD16
B33	C_BE#2	A33	N/C
B34	Ground	A34	FRAME#
B35	IRDY#	A35	Ground
B36	N/C	A36	TRDY#
B37	DEVSEL#	A37	Ground
B38	Ground	A38	STOP#
B39	PLOCK#	A39	N/C
B40	PERR#	A40	SDONE
B41	N/C	A41	SBO#
B42	SERR#	A42	Ground
B43	N/C	A43	PAR
B44	C_BE#1	A44	AD15
B45	AD14	A45	N/C
B46	Ground	A46	AD13
B47	AD12	A47	AD11
B48	AD10	A48	Ground
B49	Ground	A49	AD9
	KEY		KEY
	KEY		KEY
B52	AD8	A52	C_BE#0
B53	AD7	A53	N/C
B54	N/C	A54	AD6
B55	AD5	A55	AD4
B56	AD3	A56	Ground
B57	Ground	A57	AD2
B58	AD1	A58	AD0
B59	+5V	A59	+5V
B60	ACK64#	A60	REQ64#
B61	+5V	A61	+5V
B62	+5V	A62	+5V

2.12 Install a Different Processor



Install CPU

1. Lift the handling lever of CPU socket outwards and upwards to the other end.
2. Align the processor pins with holes on the socket. Make sure that the notched corner or dot mark (pin 1) of the CPU corresponds to the socket's bevel end. Then press the CPU gently until it fits into place. If this operation is not easy or smooth, don't do it forcibly. You need to check and rebuild the CPU pin uniformly.
3. Push down the lever to lock processor chip into the socket.
4. Follow the installation guide of cooling fan or heat sink to mount it on CPU surface and lock it on the socket 370.
5. Be sure to follow particular CPU speed and voltage type to adjust the jumper settings properly for all boards.



Remove CPU

1. Unlock the cooling fan first.
2. Lift the lever of CPU socket outwards and upwards to the other end.
3. Carefully lift up the existing CPU to remove it from the socket.
4. Follow the steps of CPU installation to change to another one or place handling bar to close the opened socket.



Configure Processor Speed

The system was designed to self-detect its CPU speed. So it does not require any system adjustment.

2.13 Use a Client Computer



Connection Using Hyper Terminal

If users use a headless PNA-3303, which has no mouse/keyboard and VGA output connected to it, the console may be used to communicate with PNA-3303.

To access PNA-3303 via the console, Hyper Terminal is one of the choices. Follow the steps below for the setup:

1. Execute HyperTerminal under C:\Program Files\Accessories\HyperTerminal
2. Enter a name to create new dial

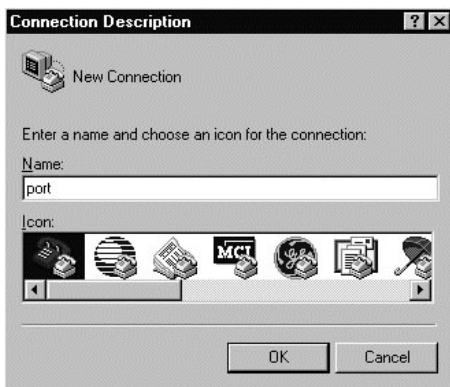

3. For the connection settings, make it Direct to Com1.



- Please make the port settings to Baud rate 19200, Parity None, Data bits 8, Stop bits 1

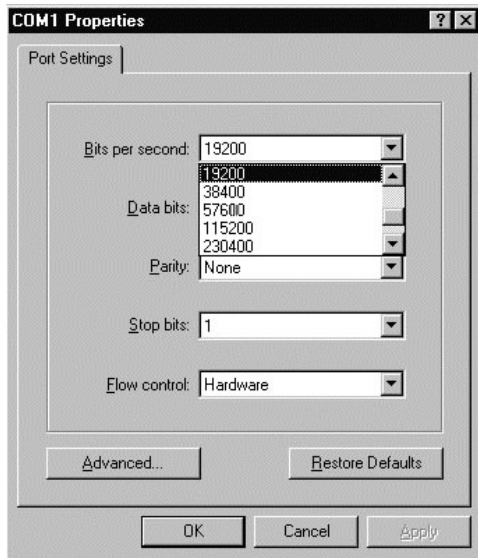

- Turn on the power of PNA-3303, after following screen was shown

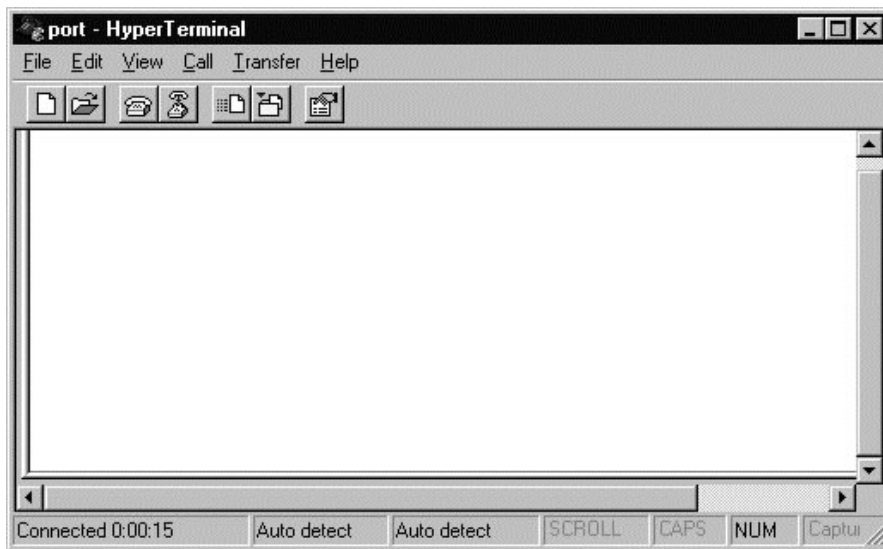

- You can then see the boot up information of PNA-3303



- This is the end of this section. If the terminal did not port correctly, please check the previous steps.

Chapter 3 Operation Guide

3.1 Brief Guide of PPAP-200

PPAP-200 is a Communication Appliance computing board based on Intel 815E chipset technology. PPAP-200 has three on-board LAN ports to serve communication appliances, such as Firewall, which needs three Ethernet ports to connect external network (internet), demilitarized zone and internal network. Different I/O management policies can be applied respectively to individual network to achieve the highest security level. One built-in PCI slot permits further expansion for WAN connection, backup connection or even customized function card. The target market segment is communication appliance including Virtual Private Network, Load Balancing, Quality of Service, Intrusion Detection, Virus Detection, Firewall and Voice Over IP.

This PPAP-200 system board is eligible with Intel® FC-PGA Celeron® and Intel® FC-PGA Pentium® III processors, and 144-pin SODIMM up to 256MB DRAM. The enhanced on-board PCI IDE interface supports 2 drives up to PIO mode 4 timing and Ultra DMA/100 synchronous mode feature. The on-board super I/O chipset integrates two serial ports driven by two high performance 16C550-compatible UARTs to provide 16-byte send/receive FIFOs. Besides, the two Universal Serial Bus ports provide high-speed data communication between peripherals and PC.

The on-board flash ROM is used to make the BIOS update easier. An AC/DC adaptor power input jack is provided for AT mode operation. The high precision Real Time Clock/Calendar is built to support Y2K for accurate scheduling and storing configuration information. All of these features make PPAP-200 excellent in stand-alone applications.

If any of these items is damaged or missing, please contact your vendor and save all packing materials for future replacement and maintenance.



Figure 3-1 PPAP-200 Board

3.2 System Architecture

The following illustration of block diagram will show you how PPAP-200 gives you a highly integrated system solution. The most up-to-date system architecture of PPAP-200 includes two main VLSI chips. It contains 82815GMCH and 82801BA ICH2 to support FC-PGA Celeron/Pentium III processor, SODIMM, PCI bus interface, USB port, SMBus communication, and Ultra DMA/100 IDE Master. The on-board super I/O chip Winbond W83627HF supports two UARTs, FDC, parallel port and hardware monitoring.

PPAP-200 has built-in Socket 370 to support Intel FC-PGA Celeron/Pentium III processor (66, 100 or 133MHz system bus) for cost-effective and high performance application. However, the FC-PGA Coppersmine-256 (Pentium III) processor provides twice the Celeron L2 Cache.

The 82815 GMCH provides a completely integrated solution for the system controller and data path components in a Celeron/Pentium III processor system. It provides optimized 64-bit DRAM interface with one 144 pin 3.3V DIMM.

The 82801BA ICH2 provides a highly integrated multifunction for the best industry applications. It supports 2-channel dedicated Ultra ATA/33/66/100 IDE master interface, Universal Serial Bus (USB) controllers and one 32-bit PCI bus interface.

All detailed operating relations are shown in *Fig. 3-2* (PPAP-200 System Block Diagram).

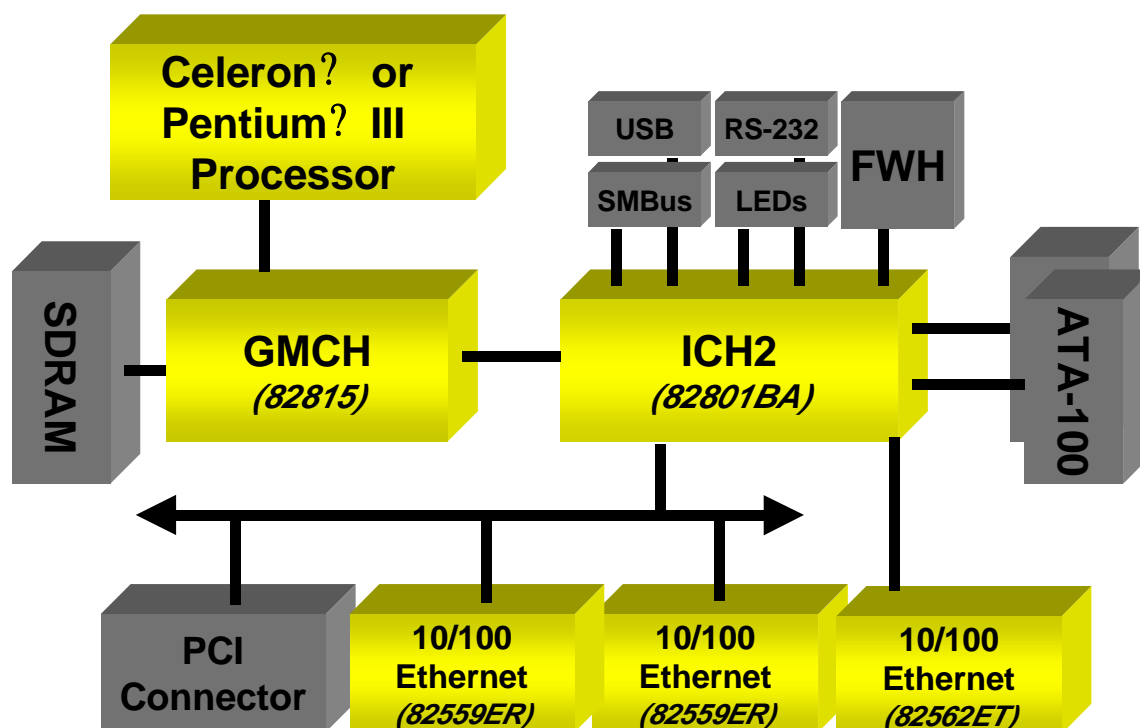

Figure 3-2 PPAP-200 815E Block Diagram